

UUT-50562

Utah 2 Floodlight - Constant Voltage



Construction

Aluminum

Less than 0.1% copper content – Marine Grade 6060 extruded & LM6 Aluminum High Pressure die casting provides excellent mechanical strength, clean detailed product lines and excellent heat dissipation.

Pre paint

8 step degrease and phosphate process that includes deoxidizing and etching as well as a zinc and nickel phosphate process before product painting.

Memory Retentive -Silicon Gasket

Provided with special injection molded "fit for purpose" long life high temperature memory retentive silicon gaskets. Maintains the gaskets exact profile and seal over years of use and compression.

Thermal management

LM6 Aluminum is used for its excellent mechanical strength and thermal dissipation properties in low and high ambient temperatures. The superior thermal heat sink design by Ligman used in conjunction with the driver, controls thermals below critical temperature range to ensure maximum luminous flux output, as well as providing long LED service life and ensuring less than 10% lumen depreciation at 50,000 hours.

Surge Suppression

Standard 10kv surge suppressor provided with all fixtures.

Finishing

All Ligman products go through an extensive finishing process that includes fettling to improve paint adherence.

Paint

UV Stabilized 4.9Mil thick powder coat paint and baked at 200 Deg C. This process ensures that Ligman products can withstand harsh environments. Rated for use in natatoriums.

Inspired by Nature Finishes

The Inspired by nature Finishing is a unique system of decorative powder coating. Our metal decoration process can easily transform the appearance of metal or aluminum product into a wood grain finish.

This patented technology enables the simulation of wood grain, and even marble or granite finish through the use of decorative powder coating.

The wood grain finish is so realistic that it's almost undistinguishable from real wood, even from a close visual inspection. The system of coating permeates the entire thickness of the coat and as a result, the coating cannot be removed by normal rubbing, chipping, or scratching.

The Coating Process

After pre-treatment the prepared parts are powder coated with a specially formulated polyurethane powder. This powder provides protection against wear, abrasion, impact and corrosion and acts as the relief base color for the finalized metal decoration.

The component is then wrapped with a sheet of non-porous film with the selected decoration pattern printed on it using special high temperature inks.

This printed film transfer is vacuum-sealed to the surface for a complete thermo print and then transferred into a customized oven. The oven transforms the ink into different forms within the paint layer before it becomes solid. Finally, the film is removed, and a vivid timber look on aluminum remains.

Wood grain coating can create beautiful wood-looking products of any sort. There are over 300 combinations of designs currently in use. Wood grains can be made with different colors, designs, etc.

Our powder coatings are certified for indoor and outdoor applications and are backed by a comprehensive warranty. These coatings rise to the highest conceivable standard of performance excellence and design innovation.

Added Benefits

- Resistance to salt-acid room, accelerated aging
- Boiling water, lime and condensed water resistant
- Anti-Graffiti, Anti-Slip, Anti-Microbial, Anti-Scratch
- Super durable (UV resistant)
- TGIC free (non-toxic)

Hardware

Provided Hardware is Marine grade 316 Stainless steel.

Anti Seize Screw Holes

Tapped holes are infused with a special anti seize compound designed to prevent seizure of threaded connections, due to electrolysis from heat, corrosive atmospheres and moisture.

Crystal Clear Low Iron Glass Lens

Provided with tempered, impact resistant crystal clear low iron glass ensuring no green glass tinge.

Optics & LED

Precise optic design provides exceptional light control and precise distribution of light.
LED CRI > 80

Lumen - Maintenance Life

L80 /B10 at 50,000 hours (This means that at least 90% of the LED still achieve 80% of their original flux)

Miniature adjustable spotlight range. Contemporary simplicity and a diminutive footprint allows designers to paint landscaping with light whilst avoiding visual clutter.

A mini floodlight designed to use a single high power LED. These floodlights are designed to illuminate plants and fulfill architectural details and sign boards. RGBW full colors render for each LEDs and static white for color temperature 2700K, 3000K, 3500K and 4000K, LED CRI >80 and life time 50,000 Hours.

Plastic ground spike for garden type. Accessory visor must be order separately. Remote driver box is not included, but is available as an accessory. This luminaire is constant voltage type and needs connecting in parallel.

This is a constant voltage fixture. It can support one driver for multiple fixtures. This fixture is non dimming

Additional Options (Consult Factory For Pricing)



A51431
Anti Glare Visor



A80191
Remote Driver Box

2w LED 164 Lumens
IP65 • Suitable For Wet Locations
IK07 • Impact Resistant (Vandal Resistant)
Weight .6 lbs

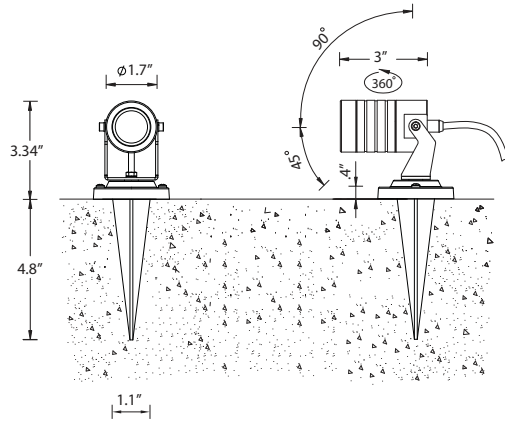

CITY OF FLAGSTAFF & TURTLE FRIENDLY COMPLIANT

AMB Spectral Diagram

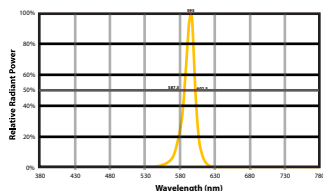

Narrow-Spectrum Amber LEDs

Peak wavelength between 585 & 595 nanometers and a full width of 50% power no greater than 15 nanometers.



UUT-50562

Utah 2 Floodlight - Constant Voltage

PROJECT		DATE	
----------------	--	-------------	--

QUANTITY		TYPE		NOTE	
-----------------	--	-------------	--	-------------	--

ORDERING EXAMPLE || UUT - 50562 - 2w LED - W30 - 02 - 120/277v

UUT-50562				
LAMP	LED COLOR	FINISH COLOR	VOLTAGE	

2w LED
164 Lumens

W27 - 2700K
W30 - 3000K
W35 - 3500K
W40 - 4000K

01 - BLACK RAL 9011
02 - DARK GREY RAL 7043
03 - WHITE RAL 9003
04 - METALLIC SILVER RAL 9006
05 - MATTE SILVER RAL 9006
06 - LIGMAN BRONZE
07 - CUSTOM RAL



120/277v
Other - Specify

--	--	--

ADDITIONAL OPTIONS

F - Frosted Lens A51431 - Anti Glare Visor
 NAT - Natatorium Rated A80191 - Remote Driver Box
 AMB - Turtle Friendly Amber LED

INSPIRED BY NATURE FINISHES

SW01 - OAK FINISH
 SW02 - WALNUT FINISH
 SW03 - PINE FINISH
 DF - DOUGLAS FIR FINISH
 CW - CHERRY WOOD FINISH
 NW - NATIONAL WALNUT FINISH
 SU01 - CONCRETE FINISH
 SU02 - SOFTSCAPE FINISH
 SU03 - STONE FINISH
 SU04 - CORTEN FINISH



THERE IS AN ADDITIONAL COST FOR THESE FINISHES

More Custom Finishes Available Upon Request

Consult factory for pricing and lead times



Example: Inspired by Nature Finish

Driver Specification - 24vdc Constant Voltage

Wattage



Depending on the quantity of fixtures on each leg, specific drivers can be provided. Please specify choices for each options below

Leg Requirements

1st Leg	2nd Leg	3rd Leg
Quantity of Fixtures <input type="text"/>	Quantity of Fixtures <input type="text"/>	Quantity of Fixtures <input type="text"/>
X	X	X
Fixture Watts <input type="text"/>	Fixture Watts <input type="text"/>	Fixture Watts <input type="text"/>
=	=	=
Total Watts <input type="text"/>	Total Watts <input type="text"/>	Total Watts <input type="text"/>

Depending on the quantity of legs, multiple drivers may be required on one project

Example

Single Fixture Wattage = 2w

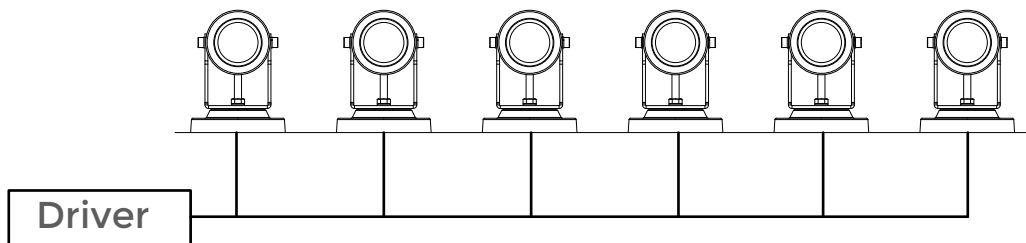

Quantity 6 fixtures x 2w = Total Drivers Required 12w
Result is to use quantity 1 - 12w Driver

NOTE: THIS IS JUST AN EXAMPLE, WATTAGES AND QUANTITIES VARY BETWEEN FIXTURES