

# UPRA-10002

## Prague 1 Small Bollard



**8w LED**  
**855 Lumens**

**IP65**  
Suitable for wet locations

**IK08**  
Impact Resistant [ Vandal Resistant]

**Weight - 10.3 lbs**



### Construction

**Aluminum.**  
Less than 0.1% copper content - Marine Grade 6060 extruded & LM6 Aluminum High Pressure die casting provides excellent mechanical strength, clean detailed product lines and excellent heat dissipation.

**Pre paint**  
8 step degrease and phosphate process that includes deoxidizing and etching as well as a zinc and nickel phosphate process before product painting.

**Memory Retentive -Silicon Gasket**  
Provided with special injection molded "fit for purpose" long life high temperature memory retentive silicon gaskets. Maintains the gaskets exact profile and seal over years of use and compression.

**Thermal management**  
LM6 Aluminum is used for its excellent mechanical strength and thermal dissipation properties in low and high ambient temperatures. The superior thermal heat sink design by Ligman used in conjunction with the driver, controls thermals below critical temperature range to ensure maximum luminous flux output, as well as providing long LED service life and ensuring less than 10% lumen depreciation at 50,000 hours.

**Surge Suppression**  
Standard 10kv surge suppressor provided with all fixtures.

**BUG Rating**  
B0 - U0 - G0

**Finishing**  
All Ligman products go through an extensive finishing process that includes fettling to improve paint adherence.

**Paint**  
UV Stabilized 4.9Mil thick powder coat paint and baked at 200 Deg C. This process ensures that Ligman products can withstand harsh environments. Rated for use in natoriums.

**Inspired by Nature Finishes**  
The Inspired by nature Finishing is a unique system of decorative powder coating. Our metal decoration process can easily transform the appearance of metal or aluminum product into a wood grain finish.

This patented technology enables the simulation of wood grain, and even marble or granite finish through the use of decorative powder coating.

The wood grain finish is so realistic that it's almost undistinguishable from real wood, even from a close visual inspection. The system of coating permeates the entire thickness of the coat and as a result, the coating cannot be removed by normal rubbing, chipping, or scratching.

**The Coating Process**  
After pre-treatment the prepared parts are powder coated with a specially formulated polyurethane powder. This powder provides protection against wear, abrasion, impact and corrosion and acts as the relief base color for the finalized metal decoration.

The component is then wrapped with a sheet of non-porous film with the selected decoration pattern printed on it using special high temperature inks.

This printed film transfer is vacuum-sealed to the surface for a complete thermo print and then transferred into a customized oven. The oven transforms the ink into different forms within the paint layer before it becomes solid. Finally, the film is removed, and a vivid timber look on aluminum remains.

Wood grain coating can create beautiful wood-looking products of any sort. There are over 300 combinations of designs currently in use. Wood grains can be made with different colors, designs, etc.

Our powder coatings are certified for indoor and outdoor applications and are backed by a comprehensive warranty. These coatings rise to the highest conceivable standard of performance excellence and design innovation.

- Added Benefits**
- Resistance to salt-acid room, accelerated aging
  - Boiling water, lime and condensed water resistant
  - Anti-Graffiti, Anti-Slip, Anti-Microbial, Anti-Scratch
  - Super durable (UV resistant)
  - TGIC free (non-toxic)

**Hardware**  
Provided Hardware is Marine grade 316 Stainless steel.

**Anti Seize Screw Holes**  
Tapped holes are infused with a special anti seize compound designed to prevent seizure of threaded connections, due to electrolysis from heat, corrosive atmospheres and moisture.

**Crystal Clear Low Iron Glass Lens**  
Provided with tempered, impact resistant crystal clear low iron glass ensuring no green glass tinge.

**Optics & LED**  
Precise optic design provides exceptional light control and precise distribution of light. LED CRI > 80

**Lumen - Maintenance Life**  
L80 /B10 at 50,000 hours (This means that at least 90% of the LED still achieve 80% of their original flux)

**A new contemporary bollard design family, meeting Dark Sky requirements, utilizing MicroVos Technology to get maximum spacing and excellent uniformity.**

Small, medium and large size LED bollards incorporates optional symmetrical and asymmetrical light distributions, in a variety of different heights. Clean architectural design with no visible hardware, at the top of the luminaire are the further characteristics of this bollard. Ideal for lighting pathways, entrances, square, and terraces.

Color temperature from 2700K, 3000K, 3500K and 4000K, LED CRI >80. Aluminum housing and extruded aluminium column with high corrosion resistance. Stainless steel fasteners in grade 316. Durable silicone rubber gasket and clear toughened glass. Powder coating with high corrosion resistance and chemical chromatized protection.

To meet International Dark Sky criteria, 3000k or warmer LEDs must be selected.

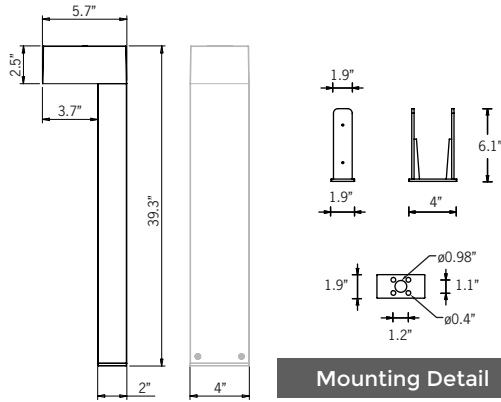

Ligman's micro Variable Optical System provides the ability to interchange, mix & rotate optics to provide specific light distributions for optimized spacing and uniformity.

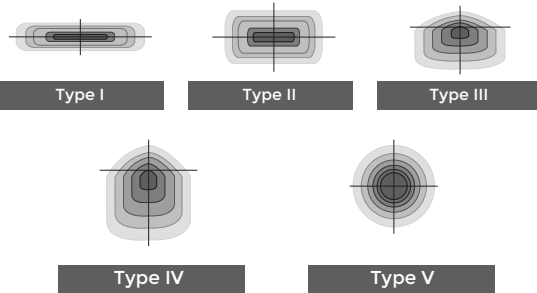

The variable optic system allows for the designer to create hybrid distributions for precise lighting requirements.

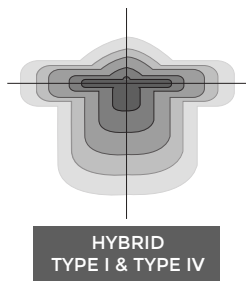

<b>PROJECT</b>		<b>DATE</b>	
----------------	--	-------------	--

<b>QUANTITY</b>		<b>TYPE</b>		<b>NOTE</b>	
-----------------	--	-------------	--	-------------	--

**ORDERING EXAMPLE || UPRA - 10002 - 8w - T2 - W30 - 02 - 120/277v - Options**

<b>UPRA-10002</b>					
<b>LAMP</b>	<b>BEAM</b>	<b>LED COLOR</b>	<b>FINISH COLOR</b>	<b>VOLTAGE</b>	
8w LED 855 Lumens	T1 - Type I Distribution T2 - Type II Distribution T3 - Type III Distribution T4 - Type IV Distribution M - Medium 32° W - Wide 52° VW - Very Wide 65° EW - Extra Wide 108°  <div style="display: flex; justify-content: space-around; font-size: 8px;"> <div style="text-align: center;">-T1- </div> <div style="text-align: center;">-T2- </div> <div style="text-align: center;">-T3- </div> <div style="text-align: center;">-T4- </div> </div>	W27 - 2700K W30 - 3000K W35 - 3500K W40 - 4000K	01 - BLACK RAL 9011 02 - DARK GREY RAL 7043 03 - WHITE RAL 9003 04 - METALLIC SILVER RAL 9006 05 - MATTE SILVER RAL 9006 06 - LIGMAN BRONZE 07 - CUSTOM RAL	120/277v Other - Specify	
			<b>INSPIRED BY NATURE FINISHES</b> SW01 - OAK FINISH SW02 - WALNUT FINISH SW03 - PINE FINISH DF - DOUGLAS FIR FINISH CW - CHERRY WOOD FINISH NW - NATIONAL WALNUT FINISH SU01 - CONCRETE FINISH SU02 - SOFTSCAPE FINISH SU03 - STONE FINISH SU04 - CORTEN FINISH		
			THERE IS AN ADDITIONAL COST FOR THESE FINISHES		

**ADDITIONAL OPTIONS**

- |   |   |
|---|---|
| NAT - Natatorium Rated<br>HGT - Custom Bollard Height | FNF - Front Face Nature Finish<br>DIM - 0-10v Dimming |
|---|---|

**Custom Finishes Available Upon Request**  
Consult factory for pricing and lead times

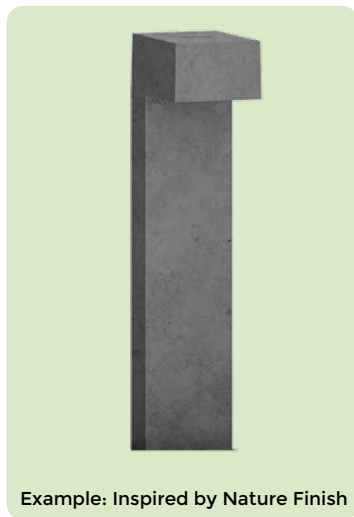

# Prague Product Family



Prague 1

- UPRA-10001-8w-855lm [19.6"]
- UPRA-10002-8w-855lm [39.3"]



Prague 2

- UPRA-10011-14w-1675lm [19.6"]
- UPRA-10012-14w-1675lm [39.3"]



Prague 3

- UPRA-10021-20w-2422lm [19.6"]
- UPRA-10022-20w-2422lm [39.3"]